

# Surface Mount Fuses

## 350 Volt Surface Mount Fuse

### EBF Fuse Fast-Acting Type 446/447 Series



- Ideal for use in electronic lighting ballast, power supply and power inverter applications.
- Rated for use in 125, 250, 277 and 350 VAC circuits.
- Based on the proven reliability of the automotive MINI® Fuse; available from 2 through 10 amperes.

#### ELECTRICAL CHARACTERISTICS:

% of Ampere Rating	Opening Time
100%	4 hours, Minimum
200%	0.15 sec. Min., 5 Sec. Max

**AGENCY APPROVALS:** Recognized under the Components Program of Underwriters Laboratories and CSA Certified. Approved by METI to 5 amperes.

**AGENCY FILE NUMBERS:** UL: E71611, CSA LR 29862.

**INTERRUPTING RATINGS:** 100 amperes at 350 VAC, 50 amperes at 125 VDC and 450 amperes at 60VDC

#### ENVIRONMENTAL SPECIFICATIONS:

**Operating Temperature:** -40°C to +125°C.

#### PHYSICAL SPECIFICATIONS:

**Materials:** Body: Plastic Body

Terminations: Tin-Lead (95/5) plated Zn, Ni barrier

#### Soldering Parameters:

- Reflow Solder — 235°C, 5 seconds maximum.
- No-clean process recommended.
- Wave Solder — Not recommended.
- Non-plated terminal surfaces may not meet MIL-STD-202, Method 208.

#### PACKAGING SPECIFICATIONS:

- 24mm Tape and Reel per EIA-RS481 (Equivalent to IEC 286, part 3); 800 fuses per reel, add packaging suffix, ZR.
- Shelf Life: Up to 1 year in Factory sealed packaging.

#### ORDERING INFORMATION:

Catalog Number	Ampere Rating (A)	Voltage Rating (VAC)	Nominal Cold Resistance(Ω)	Nominal Melting I <sup>2</sup> t (A <sup>2</sup> sec)
0446 002.	2	350	0.0560	2.8
0446 003.	3	350	0.0340	9.4
0446 004.	4	350	0.0240	17
0446 005.	5	350	0.0180	25
0446 07.5	7.5	350	0.0110	68
0446 010.	10	350	0.0073	93

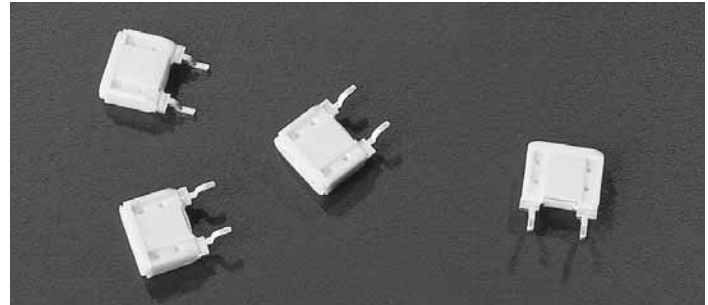

#### Reference Dimensions (Inches):

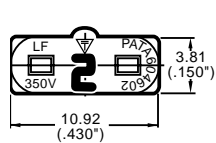

#### Recommended Pad Layout:

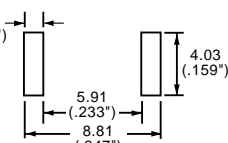

#### 447 Mounting Holes:

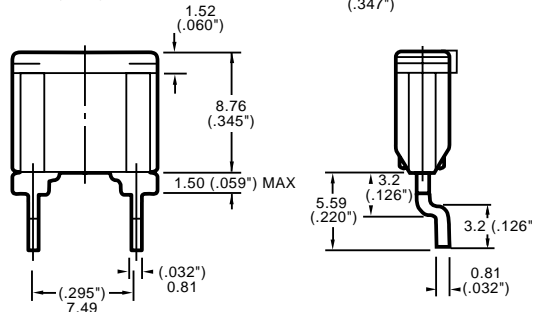
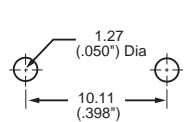

#### Average Time Current Curves

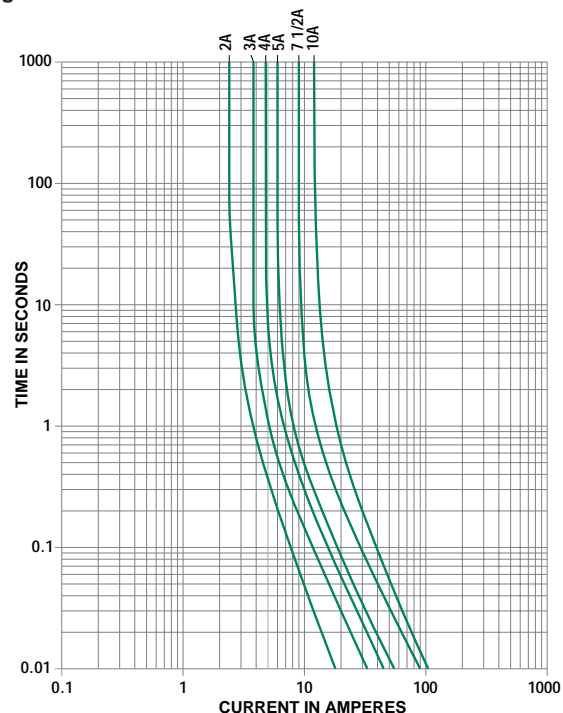

### EBF Fuse Fast-Acting Type 447 Series

- Through-hole version of the 446 series.
- ELECTRICAL CHARACTERISTICS:** Same as 446 Series.

**Dimensions:** Contact Littelfuse for specifications.

**Soldering Parameters:** Contact Littelfuse for soldering parameters. Inside terminal face of each lead is non-plated zinc. Non-plated zinc terminal faces may not meet MIL-STD-202, method 208. To ensure that the fuse is acceptable for the application, appropriate application testing should be performed.

**Packaging Specifications:** Bulk Pack (4,000 pieces per pack)