

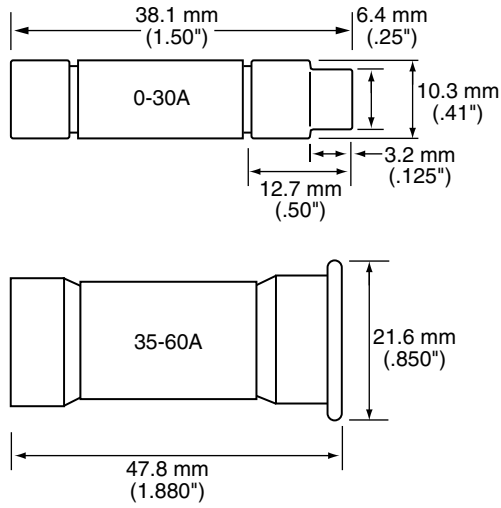

# Axial Lead and Cartridge Fuses

Midget

## Class CC Fast-Acting & Slo-Blo® Type Fuses



Average Time Current Curve (CCMR)

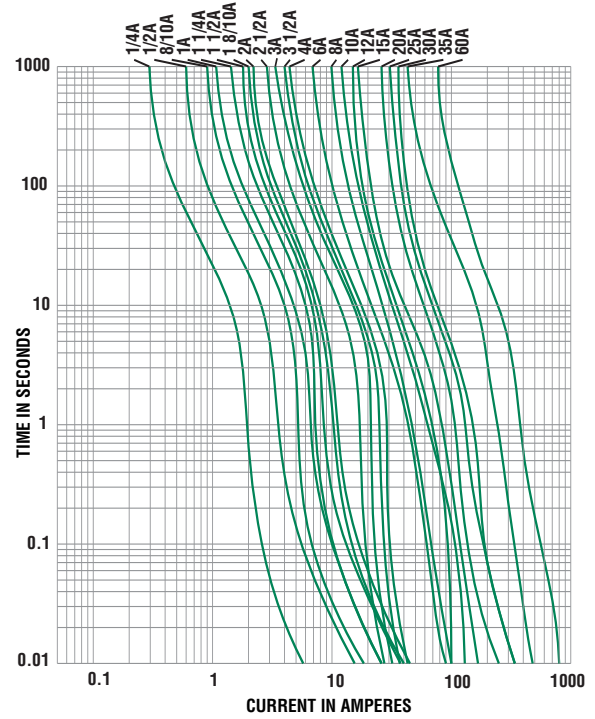

Average Time Current Curve (KLDR)

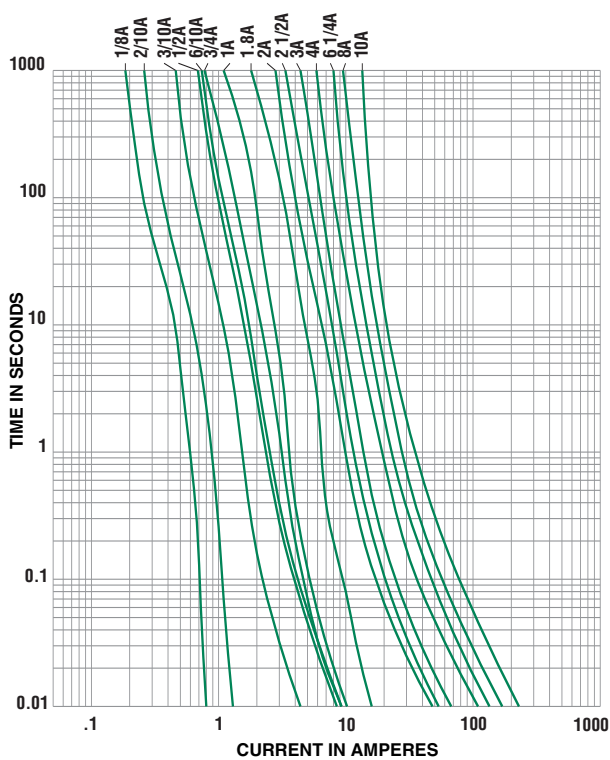

Average Time Current Curve (KLKR)

