

APPLICATION NOTE AN-107

Linear Optocouplers



CLARE

Introduction

This application note describes isolation amplifier design principles for the LOC Series linear optocoupler devices. It describes the circuit operation in photoconductive and photovoltaic modes and provides some examples of applications in different industry segments. The LOC product is intended to give the designer an alternative to bulky transformers and “non-linear” optocouplers for many applications.

Galvanic isolation is required for many circuits found in Telecommunication, Industrial, Medical and Instrumentation systems. This has been traditionally accomplished by means of transformers and optocouplers with transformers being used to couple AC signals and optocouplers used primarily for DC signal coupling. Unlike standard optocouplers, the LOC operates in a servo mode configuration which compensates for the LED’s non-linear time and temperature characteristics. In addition, the LOC can couple both AC and DC signals.

The following are examples where galvanic isolation is required:

- Telecommunications: Telecom products such as modems require isolation and signal coupling from the telephone line to the modem data pump.
- Industrial Control: Products such as temperature sensors and controllers. Temperature sensors are often remotely located from the controller and reside in hazardous environments near high voltage lines. Isolation provides the required signal coupling while insuring safety to personnel working with the controller.
- Medical: EEG and ECG machines have sensors that attach to the patient. The sensors are galvanically isolated to provide a high voltage isolation barrier between patient and machine.
- Instrumentation: Often use isolated switching supplies where it is required to sense the output voltage and feedback a portion of the signal to the controller for voltage regulation while not compromising power supply isolation.

Description

The LOC Series (LOC110, LOC111 and LOC112 with one optocoupler per package, and LOC210 and LOC211P with two per package) are linear optocouplers designed to be used in applications where galvanic isolation is required for AC and DC signal coupling and linearity from input to output must be accurately preserved. The device consists of an infra-red LED optically coupled with two phototransistors. One phototransistor is typically used in a servo feedback mechanism to control the LED drive current which has the effect of compensating for the LED’s non-linear time and temperature characteristics. The other output phototransistor is used to provide the galvanic isolation between the input and output circuit. A typical isolating amplifier is shown in figure 1.

Circuit Operation Utilizing the LOC110

Photoconductive Operation

With V_{IN} at 0V and I_F at 0mA, U1 has large open loop gain. As V_{IN} begins to increase, the output of U1 begins to go to the V_{CC1} rail. As it does, I_F current begins to flow and the LED begins to turn on. As the LED turns on, the incident optical flux on the servo phototransistor causes a current I_1 to flow. As I_1 flows through R1, a voltage is developed on the inverting input of the op amp V_A such that the output of the amplifier will begin to go to the negative supply rail (ground in this case). When the voltage on V_A is equal to V_{IN} , I_F will no longer increase and the circuit is now in a stable closed loop condition. If V_{IN} is modulated, V_A will track V_{IN} . The flux generated by the LED is also incident on the output phototransistor and generates a current I_2 which is proportional to the LED flux and LED current; this current closely tracks I_1 . The output voltage of the amplifier is the product of the output photocurrent I_2 and resistor R2. The equations and definitions of the circuit are listed below (including figure 1).

Servo Gain - K1

Defined as the ratio of the servo photocurrent I_1 to the LED forward current I_F : $K1 = I_1/I_F$.

For the LOC110, K1 is typically 0.007 for an I_F of 10mA and a V_{CC} of 15V.

Forward Gain - K2

Defined as the ratio of the output photocurrent to the LED forward current I_F : $K2 = I_2/I_F$.

K2 is typically 0.007 for an I_F of 10mA and V_{CC} of 15V.

Transfer Gain - K3

Defined as the ratio of K2 to K1: $K3 = K2/K1$.

Design Example: (Refer to figure 1)

For an input span of 0 to 2V, an output of 0 to 4V is desired. Values for R1 and R2 need to be determined. Both amplifiers will have an independent V_{CC} of +5V.

Determining R1:

Since the product of the servo photocurrent I_1 and R1 will track V_{IN} :

- $V_{IN} = I_1 \cdot R1$

Now I_1 is the photocurrent generated by the LED flux. The LED flux is generated by the LED current I_F . I_1 is proportional to I_F and the LED flux by the proportionality constant K1, which has been defined as the servo gain:

- $I_1 = K1 \cdot I_F$

To best determine R1, the maximum desired value of I_F should be used in the above equation that would correspond to a maximum V_{IN} of 2V. For this example an op amp output of 15mA is selected. Substituting equation #2 for I_1 in equation #1 and solving for R1 yields:

- $R1 = \frac{V_{IN}}{(K1 \cdot I_F)}$

Using the minimum value of 0.004 for K1 and substituting 2V for V_{IN} and 15mA for I_F (max.) gives a value of 33.3K Ω .

Determining R2:

The output voltage V_{OUT} is related to R2:

- $V_{OUT} = I_2 \cdot R2$

Photocurrent I_2 is proportional to the LED flux and LED current I_F by the proportionality constant K2:

- $I_2 = I_F \cdot K2$

Substituting equation #5 for I_2 in #4 and solving for R2:

- $R2 = \frac{V_{OUT}}{(I_F \cdot K2)}$

where $I_F=15\text{mA}$, $K2 = 0.004$, $V_{OUT} = 4\text{V}$

Substituting the above values gives an R2 of 66.6K Ω .

The amplifier will produce a 4V output when a 2V input is applied. A plot of V_{IN} vs. V_{OUT} is shown in figure 2. Photoconductive amplitude and phase response is shown in figures 2A and 2B, respectively.

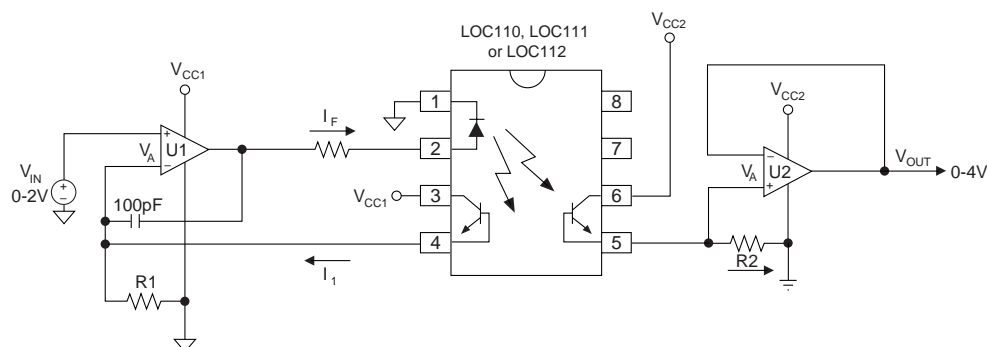

Figure 1. Isolation Amplifier (Photoconductive Operation)

The following derivation ties the example and definitions to one equation relating all the parameters for this circuit:

Solving equation #3 for V_{IN} :

$$7. V_{IN} = I_F \cdot K1 \cdot R1$$

Combining equation #4 and #5 and solving for V_{OUT} :

$$8. V_{OUT} = I_F \cdot K2 \cdot R2$$

Dividing equation #7 by equation #8 and solving for V_{OUT} gives the final equation:

$$9. V_{OUT} = \frac{V_{IN}(K2 \cdot R2)}{(K1 \cdot R1)}$$

and since the definition of $K3$ is $K3 = K2/K1$ we can further simplify by writing:

$$10. V_{OUT} = V_{IN} \cdot K3 \cdot \frac{R2}{R1}$$

I_F was canceled out of equation #10. This is due to the fact that both servo and output photocurrents originate from the same LED source. Since $K3$ is the ratio $K2/K1$, in our example $K1 = K2 = 0.004$, and $K3 = 1$.

Therefore, V_{OUT} is directly proportional to the ratio of $R2/R1$.

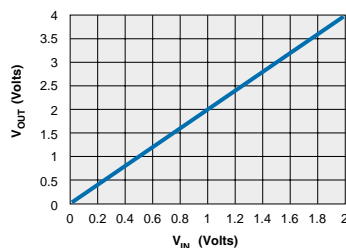

Figure 2. V_{IN} vs. V_{OUT}

The circuit in figure 1 is configured with the phototransistor collector to base reverse biased. This is operation in the photoconductive mode. When an application requires amplifier bandwidth of up to 200kHz, the photoconductive configuration should be used. This mode has linearity and drift characteristics comparable to a 8-bit D/A converter with ± 1 bit linearity error.

Photovoltaic Mode

Using the LOC product in the photovoltaic mode achieves the best linearity, lowest noise and drift performance. It is possible to achieve up to 14-bit D/A linearity in this mode. The tradeoff with this topology is that bandwidth is limited to about 40kHz. A typical isolation amplifier in the photovoltaic configuration is shown in figure 3.

In the photovoltaic mode, the LOC phototransistors act as current generators. Since all photogenerators display some voltage dependence on linearity, maintaining a 0V bias on the phototransistor eliminates this problem and improves linearity. If the phototransistor is connected across a small resistance, the output current is linear with increases in incident LED flux. To accomplish this, the phototransistors are connected across the op amp inputs. As V_{IN} increases, the current through the LED increases and so does the optical flux. The LED flux is incident on the servo phototransistor which starts current I_1 to flow from the op amp inverting input through the phototransistor. This servo photocurrent is linearly proportional to V_{IN} , $I_1 = V_{IN}/R1$ and keeps the voltage on the inverting input equal to zero.

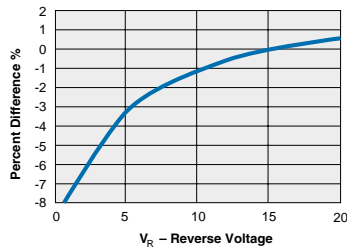

Figure 2A. Photoconductive Amplitude Response

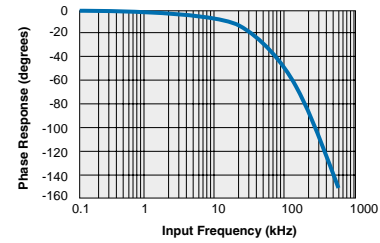

Figure 2B. Photoconductive Phase Response

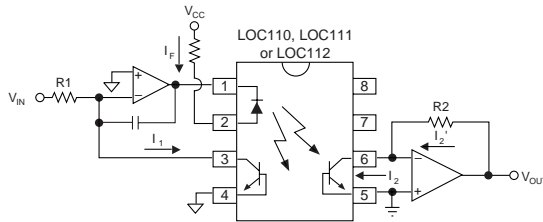

Figure 3. Isolation amplifier (Photovoltaic Operation)

The flux from the LED is also incident on the output phototransistor which causes a current I_2 to flow from the inverting input of the output op amp through the phototransistor. As I_2 is pulled from the inverting node, the output of the amplifier begins to go high until a current equal in magnitude to I_2 is injected into the inverting node of the amplifier. Since this current, I_2' , flows through R2, an output voltage is developed such that $V_{OUT} = I_2' \cdot R2$. Since $I_2 = I_2'$, $V_{OUT} = I_2 \cdot R2$. The composite equation describing the operation of this circuit is the same as in the photoconductive mode, that is: $V_{OUT} = V_{IN} \cdot K3 \cdot R2/R1$.

The frequency and phase response for this circuit is shown in figures 4 and 5 respectively. This circuit has a bandwidth of approximately 40kHz.

Using the LOC210P or LOC211P in a Modem Data Access Arrangement (DAA) Circuit.

Background

In the past, the only way to couple signals from the telephone line and provide the isolation necessary has been to use a transformer. With the advent of pocket and PCMCIA (Personal Computer Memory Card International Association) modems, however, the transformer has become a liability in terms of the size, weight and PCB real estate it occupies. Today, PCMCIA modems demand rugged on-board DAA circuits. The LOC eliminates the transformer problem with no performance sacrifice and improved manufacturability and reliability. With Total Harmonic Distortion typically at -87dB and servo non-linearity less than 0.01%, the LOC210P is well suited for high speed modem applications.

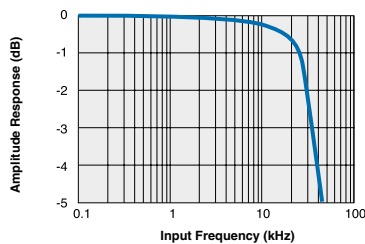

Figure 4. Photovoltaic Amplitude Response

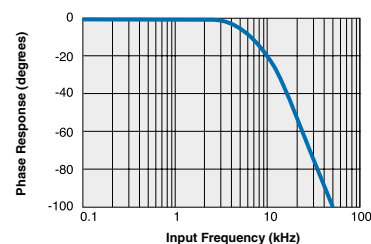

Figure 5. Photovoltaic Phase Response

Description

One LOC210P or LOC211P is required for full duplex operation. One half of the LOC is used in the transmit path and the other in the receive path. The photovoltaic mode of operation is usually selected for high speed modem circuits due to the improved linearity and lower noise. Figure 6 shows a schematic of this DAA. The LOC210P or LOC211P is connected in a similar manner to the circuit shown in Figure 3. While there are many ways to design a DAA with the LOC, the figure is intended to be used by the designer as a possible starting point.

Transmit Path

Referring to Figure 6, the TX input of the DAA is AC coupled to the modem's data pump transmit signal via C1. Resistor R5 pre-biases the input amplifier such that a quiescent forward current in the LED is established. The transmit signal from the modem will modulate the LOC LED current above and below this quiescent current. Transistor Q2 provides drive current for the LED. This is required to prevent hard output loading of the op amp which would increase Total Harmonic Distortion (THD) and increase non-linearity. The output of the amplifier is AC coupled via C8 to the base of Q1. Q1 modulates the loop current on the telephone line in response to the transmit signal thus transmitting the modem's signal over the telephone line.

Recieve Path

The receive signal across tip and ring is coupled through R1 and C3 to the input of the isolation amplifier. The receive amplifier drives the LOC LED which takes its power from across the telephone line. The LOC couples this signal which is then AC coupled via C4 and then goes to the receive input of the modem's data pump.

Echo Cancellation

The transmit signal is removed from the receive path by taking advantage of the inherent signal phase shifts around Q1. The transmit signal on the emitter is 180 degrees out of phase with the transmit signal on the collector. R1 and R2 can be selected such that the transmit signal is essentially canceled out on the node of R1 and R2 while not effecting the receive signal. This cancellation or "trans-hybrid loss" can exceed 30 dB with 1% resistor values and careful matching. R4 and C5 form an impedance network of 600Ω. Another benefit from R4 and C5 is that it provides V_{CC2} with AC rejection which is used to power the isolating amplifiers on the line side of the circuit.

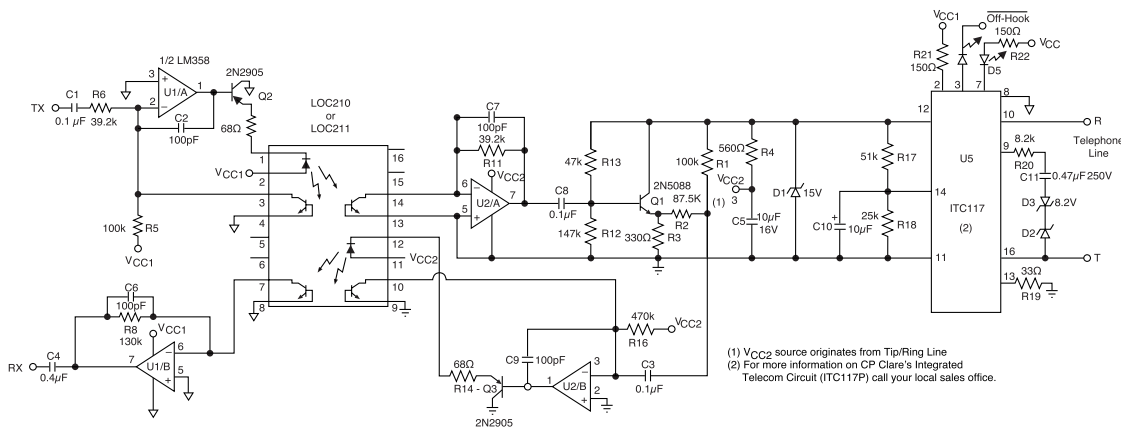

Figure 6. Typical Modem DAA using the LOC210P

Electronic Inductor

The purpose of the electronic inductor circuit is to sink loop current when the modem goes off-hook thus seizing the phone line. The circuit usually consists of a Darlington transistor, a resistor bias network, and a capacitor to provide AC rejection. This circuit should be designed to work throughout the range of loop currents per FCC Part 68.3. The circuit also presents a high AC impedance to the line so that signal integrity is not compromised. The zener diode is installed for protection of the Darlington transistor and other circuitry on the line side. The zener voltage is selected based on the voltage rating of the other components selected. Refer to Appendix 1 for details on the electronic inductor design.

Switch Mode Power Supply Application (LOC110, LOC111 or LOC112)

Another useful application for the LOC110, LOC111 or LOC112 is in the feedback control loop of isolated switching power supplies. Typically, the DC output voltage of the supply is monitored and fed back to the control input of the switcher through isolated means in order to regulate the output voltage. The most common way of doing this in the past has been to use an additional winding on the isolation transformer, figure 7A.

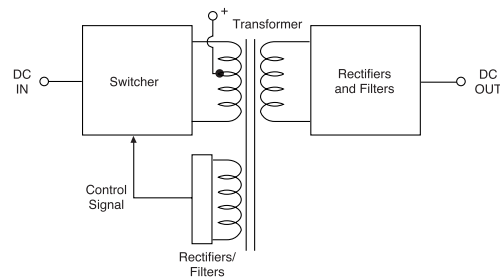

Figure 7A. DC-to-DC Converter with Feedback Winding

This winding would generate an AC signal which then needed to be rectified, filtered, and possibly scaled down with a resistor network before going into the control input of the switcher. Using the LOC110, LOC111 or LOC112 to accomplish the same task is a better solution since the special transformer windings, rectification, and filtering are eliminated. Also, the problem of poor load regulation due to inadequate winding coupling is eliminated. Referring to figures 7B and 7C, the design is almost identical to the basic photoconductive isolated unity gain amplifier discussed previously, however a voltage divider consisting of R_A and R_B is added.

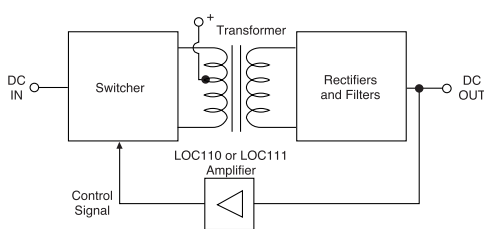

Figure 7B. DC-to-DC Converter with LOC110, LOC111 or LOC112 (Block Diagram)

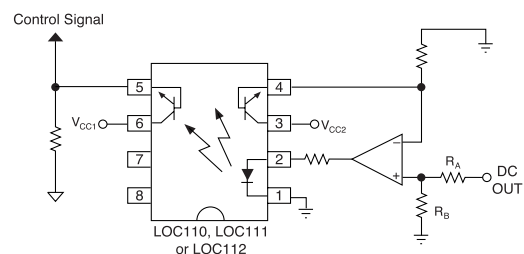

Figure 7C. DC-to-DC Converter with LOC110, LOC111, or LOC112 (Schematic)

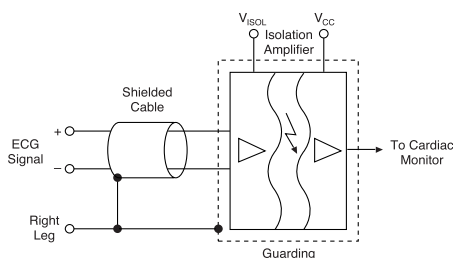

Figure 8. LOC110 Isolated Amplifier in ECG Application

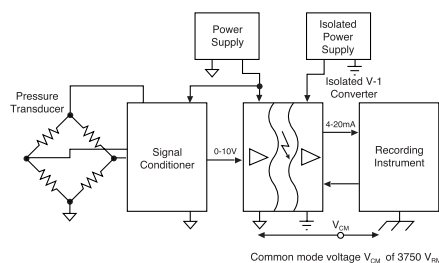

Figure 9. Isolated Pressure Transmitter

Cardiac Monitoring Application

Designing equipment to measure Cardiac signals such as the Electrocardiogram (ECG) presents some special problems. Cardiac signals for adults are approximately 1mV in magnitude while for a fetus can be as low as 50µV. Since the heart signals are low in amplitude, noise such as residual electrode voltages and 50/60Hz power line pickup can easily swamp out the signal. Therefore, it is important to design an isolated amplifier circuit which interfaces to the probe that has high Common Mode Rejection (CMR) ratings to reduce or eliminate common mode noise while providing amplification for the heart signals.

The LOC110, LOC111 or LOC112, with the proper support circuitry, can provide the isolation, amplification, linearity, and high CMRR that is required for this type of application. Referring to the diagram in figure 8, the isolated amplifier block contains the LOC110, LOC111 or LOC112 and high CMRR op amps. The electrodes are connected to the amplifier via shielded cable to provide noise immunity. The shield is connected to the patient's right leg for best CMR performance. For good performance, proper shielding, PCB layout and amplifier, design techniques should be practiced.

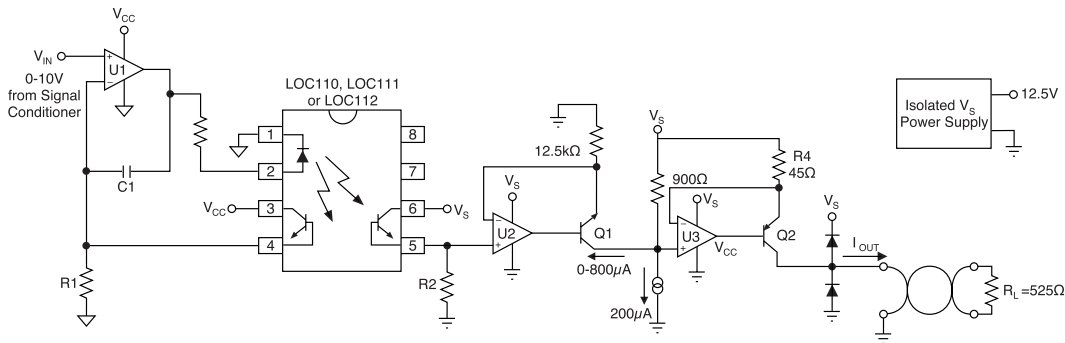

Figure 9B. 0-10V to 4-20mA Converted

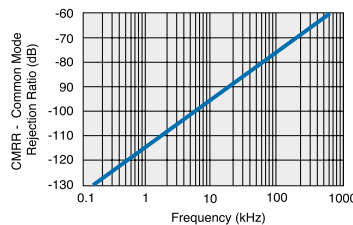

Figure 9A. Common Mode Rejection

Isolated 0-10V to 4-20mA Converter Application

Industrial controllers and data acquisition equipment frequently require an isolated voltage-to-current loop converter in environments where high common mode noise exists and protection of equipment and personnel from high voltages are required. The current loop, usually 4-20mA, is used to drive control valves or the input to chart recorders for temperature/pressure monitoring over time for example. Figure 9 shows a simplified block diagram of an isolated pressure transmitter.

The LOC110, LOC111 or LOC112, with a typical Common Mode Rejection Ratio of 130dB (see figure 9A) and isolation voltage up to 3750V_{RMS} (E version) is a good choice for this kind of application. The example circuit for this application is shown in figure 9B. The LOC110, LOC111 or LOC112 is in the photoconductive mode which has linearity comparable to an 8 bit D/A converter with ±1 LSB nonlinearity or 0.39% of full scale.

For this example, the input to the circuit is 0-10V from the output of the pressure transducer signal conditioner, R1 and R2 are calculated based on the K3 of the LOCs being used and should be selected to achieve unity gain for the amplifier. Note that the isolation amplifier portion of the circuit is very similar to the basic photoconductive amplifier discussed earlier. The difference is the addition of pass transistor Q1 in the negative feedback loop of U2. V_{CC} is the non-isolated power supply and V_S is the isolated power supply which is 12.5V for this example. This supply does not require strict regulation as U3 maintains current regulation for the loop.

When a 0V input is applied to U1 from the signal conditioner, Q1 will be off and not sink any current. The constant current source connected to the non-inverting input of U3 sinks a continuous current of 200 μ A. A device such as the LM341A zener shunt regulator can be configured as a constant current source for this purpose. This current is converted to a 4mA current by U3, Q2, and R4 which drives the load R_L . When V_{IN} is 10V, transistor Q1 sinks 800 μ A of current. This 800 μ A, plus the constant current of 200 μ A, result in an I_{OUT} of 20mA delivered through the load R_L . The two 1N4001 diodes are installed for protection when driving inductive loads. V_{IN} vs. I_{OUT} is shown in figure 10.

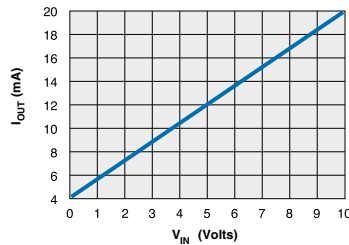

Figure 10. V_{IN} vs. I_{out}

Summary

Here are some guidelines when designing with the LOC:

1. Use photoconductive mode for applications where up to 200kHz bandwidth is required and linearity comparable to an 8-bit D/A converter with ± 1 LSB (Least Significant Bit) linearity error is acceptable.
2. Use photovoltaic mode where up to 40kHz bandwidth is required and linearity comparable to a 13-to-14 bit D/A converter with ± 1 LSB linearity error (0.01%) is acceptable.
3. Drive LED with a transistor buffer to maintain the best linearity and to keep Total Harmonic Distortion (THD) to a minimum.
4. For high resistance values (>30K), it may be necessary to put a 100pF capacitor from the output of the op-amp to the input as shown in figure 1. This will help prevent oscillations.
5. For bipolar operation, select a quiescent LED current. The superimposed AC input signal will swing above and below this current. A quiescent LED current is generated by pre-biasing the op amps such that in the absence of an AC signal, a current flows through the LED.

The following is a brief list of possible op amps[†] which may be used in conjunction with the LOC Series:

- LMC6484
- LM358
- LM201
- LM1558

[†]Please note this is not a complete listing of op amps.

Table 1. Typical Applications Using the LOC110/LOC210P

Industry Segment	Application	Mode	Function
	Modem DAA	PV Mode for best linearity 0.01%	H.V. Isolation, Signal Coupling with — 40KHz bandwidth
	PBX Isolated SWPS* for Ring Generator	PC Mode for 200KHz bandwidth 0.39% linearity	Isolated voltage sensing for SWPS* feedback
Industrial	Industrial RTD (Resistance Temp. Device)	PV or PC depending on desired linearity and bandwidth	High CMRR** for noise immunity, HV isolation, signal coupling
	Isolated Pressure Sensing	PV or PC depending on desired linearity and bandwidth	High CMRR** for noise immunity, HV isolation, signal coupling
	Isolated 4-20mA Converters	PV or PC depending on desired linearity and bandwidth	High CMRR** for noise immunity, HV isolation, signal coupling
Medical	Isolated EGG/ECG Amplifier	PV or PC depending on desired linearity and bandwidth	Couples low level signals from transducers, HV isolation, noise immunity
Instrumentation	PH Probe	PV Mode	Maintains high CMRR** for remote PH probe, provides amplification and HV isolation

*SWPS: Switch Mode Power Supply **CMRR:Common Mode Rejection Ratio

Appendix 1

Electronic Inductor Design

The electronic inductor approximates the operation of a discrete inductor by using a Darlington transistor, three (3) resistors and a capacitor. When used in a modem application, the electronic inductor will present a relatively low impedance to DC currents and a relatively high impedance to AC signals.

Circuit Description

Figure 1 shows the electronic inductor in a typical modem environment. Bridge D2 rectifies current on tip and ring for the electronic inductor only. This ensures line-polarity insensitivity required by most regulatory agencies. Diode D1 protects Darlington Q1 from excessive transient voltages when going off-hook. The zener voltage should be less than the V_{CEO} of the Darlington. R1 and R2 set the biasing point for Q1. C1 is used for AC rejection of signals at the base of Q1. C1 should be a good quality Tantalum rated at a minimum of 10WV. R3 is used to provide negative feedback for Q1 so that Q1 will not go into saturation over the loop current range. The AC signal path is coupled to the modem's transformer via C2. C2 should have a working voltage of 100V, or 50V if two capacitors are used, one on each lead of the primary (see figure 1).

DC Characteristics (Figure 2)

The electronic inductor should be tailored to meet the following requirements:

- CO (Central Office) Battery (42.5 - 56.5V DC)
- Loop Resistance (400 - 1740 Ω)

Maximum allowed DC-resistance of CPE (Customer Premise Equipment) in off-hook mode (200 Ω) per FCC 68.314 (c1), (c2).

Minimum recommended DC resistance in off-hook mode (90 Ω) per EIA-496A, 4.2.2.1.

The two extremes of operation are as follows:

1. Minimum loop current:

- CO battery drops to 42.5V DC
- Loop resistance is 1740Ω
- Electronic coil has highest DCR of 200Ω resulting in a minimum loop current of 22mA

2. Maximum loop current:

- CO battery is 56.5V DC
- Loop DC resistance is 400Ω
- Electronic coil has the lowest DCR of 90Ω the resulting maximum current is 115mA

The circuit should be tested per FCC 68.314 which consists of a battery and variable resistor to simulate proper operation at the above stated conditions.

AC Characteristics

For good performance, the electronic inductor should emulate an inductance of between 4-10H. To approximate the value of the inductor: $L \approx R1 \cdot C1 \cdot R3$.

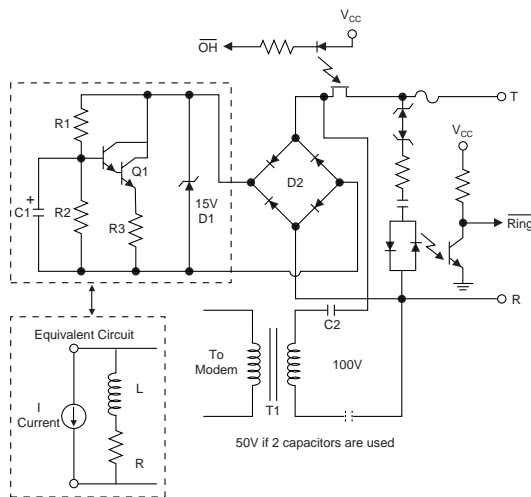

Figure 1. Dry Circuit with Electronic Inductor

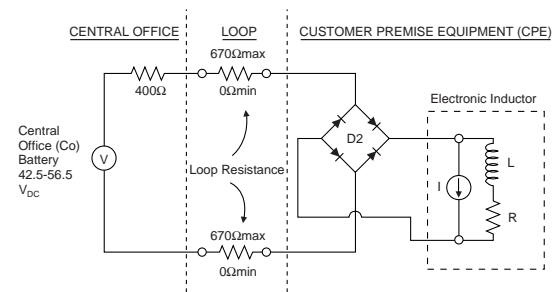

Figure 2. Central Office to CPE Interconnect

Appendix 2

Photoconductive Description

When the LOC is used in the photoconductive mode, the phototransistors are operated with the collector and base reversed biased as shown in figure 1A. The equivalent circuit model is shown in figure 1B which shows the photocurrent source I, dark current component I_D, intrinsic diode D, and junction capacitance C_P. The incident flux from the LED on the phototransistor causes a photocurrent (I) to flow from the collector to the base and through the load resistor R_L. This photocurrent is linearly proportional to the LED flux. The output voltage V_O results from the product of the photocurrent (I) plus a small dark current times the load resistance R_L: V_O=[I+I_D]•R_L. The dark currents from both phototransistors track closely and are canceled when used in the servo mode.

One of the attributes of the photoconductive mode is a bandwidth of about 200kHz. This is considerably higher than the photovoltaic mode bandwidth discussed earlier which was around 40kHz. One of the reasons for this is that with the photoconductive mode, since the base-collector junction is reversed biased, the depletion area of the junction is wider than when no bias or forward bias is applied. The wider depletion area of the junction results in a lower junction capacitance (C_P in figure 1B) which results in a faster rise time or responsivity:

$$t_R = R_L \cdot C_P$$

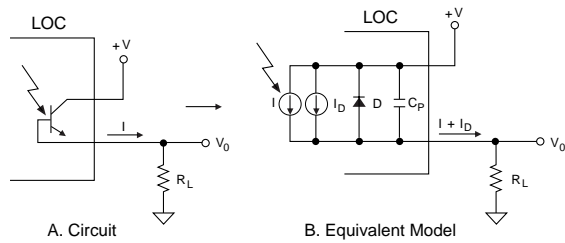

Figure 1. Photoconductive Model

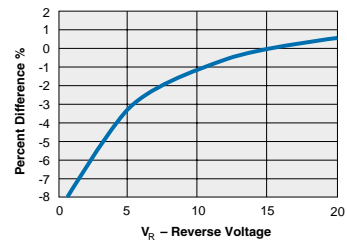

Figure 2. Photoconductive Responsivity

As the magnitude of the reverse bias is increased, the depletion width of the junction gets wider resulting in lower junction capacitance C_p .

The responsivity of the phototransistor in this mode is shown in figure 2. Note that the responsivity decreases only 3% from a +V of 15V to 5V.

Photovoltaic Description

When the LOC is used in the photovoltaic mode the phototransistors are operated with the collector and base forward biased. Figure 3 shows a typical circuit with a simplified model. In this mode the phototransistor has no external power source available to it like in the photoconductive mode where there was a +V source at the collector. Instead, the phototransistor delivers power to an external load, R_L , in response to the LED emission. Since there is no external power source connected to the phototransistor there is no dark current.

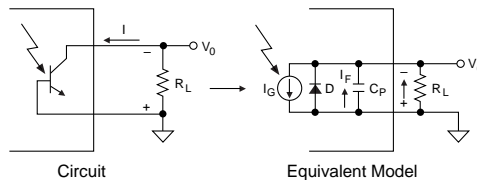

Figure 3. Photovoltaic Model

Referring to figure 3, as the current I increases with an increase in incident LED flux, a voltage is developed across R_L . This voltage however becomes increasingly nonlinear as more current (I_F) begins to flow through the intrinsic diode D or as R_L is increased in value. This can be illustrated by looking at a simplified equation of the current flow through the junction. The total current consists of two parts, one part is the current that flows through the intrinsic diode I_F , the other is the photogenerated current from the LED flux I_G :

$$I(\text{total}) = I_F - I_G.$$

I_F can be expressed with the diode equation:

$$I_F = [I_s (e^{\frac{V_0}{K}} - 1) - I_G]$$

the total current can be expressed as:

$$I_F = I_s (e^{\frac{V_0}{K}} - 1)$$

As R_L approaches 0Ω the output voltage V_0 approaches $0V$ at which time the diode term for the current equation drops out and the total current is equal in magnitude to the photogenerated current I_G which is linearly proportional to the incident LED flux:

$$I(\text{total}) = I_G \text{ with } R_L = 0\Omega$$

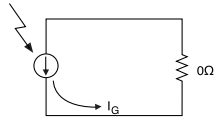

Figure 4. Equivalent Circuit with $R_L = 0\Omega$

The equivalent circuit with $R_L = 0\Omega$ is shown in figure 4.

To achieve 0V bias, the configuration shown in figure 5 is implemented. The inverting input of the amplifier is at virtual ground so a 0V bias is obtained. When LED flux is incident on the phototransistor, a current is generated by the phototransistor and pulled from the inverting input. Since by Kirchoff's law the sum of the currents entering and leaving a node must be zero, the amplifier responds with a current I_1 of equal magnitude to the current leaving the node I_G , and is injected into the inverting node via R_F which maintains zero volts at this node. The output voltage of the op amp is the current $I_1 \cdot R_F$.

The junction capacitance is higher than in the photoconductive configuration due to a zero volt bias which results in a narrower depletion region and a higher junction capacitance which limits the bandwidth to approximately 40kHz.

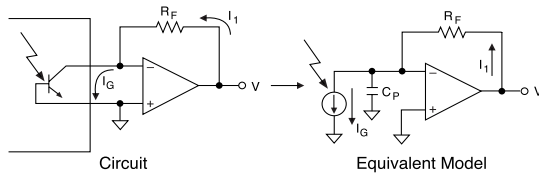

Figure 5. Implementation of 0V Bias in Photovoltaic Mode



CLARE

For additional information please visit our website at: www.clare.com

Clare, Inc. makes no representations or warranties with respect to the accuracy or completeness of the contents of this publication and reserves the right to make changes to specifications and product descriptions at any time without notice. Neither circuit patent licenses nor indemnity are expressed or implied. Except as set forth in Clare's Standard Terms and Conditions of Sale, Clare, Inc. assumes no liability whatsoever, and disclaims any express or implied warranty, relating to its products including, but not limited to, the implied warranty of merchantability, fitness for a particular purpose, or infringement of any intellectual property right.

The products described in this document are not designed, intended, authorized or warranted for use as components in systems intended for surgical implant into the body, or in other applications intended to support or sustain life, or where malfunction of Clare's product may result in direct physical harm, injury, or death to a person or severe property or environmental damage. Clare, Inc. reserves the right to discontinue or make changes to its products at any time without notice.

Specification: AN-107-R2.0
©Copyright 2002, Clare, Inc.
All rights reserved. Printed in USA.
6/25/02